

# FEATURES

- HIGH RELIABILITY FOR LOW COST
- EXTENDED TEMPERATURE RANGE TO -40/+125°C
- EXCELLENT CLOCK SIGNAL GENERATOR FOR CPU'S
- QUALIFIED FOR QUOTMOTIVE APPLICATIONS
- A LOT OF DIFFERENT PACKAGES AND DELIVERY FORMS FOR MEETING EVERY REQUIREMENT

PROCESSOR TYPE		CONEXANT/BROOKTREE BT848A OR BT878A
SERIES		HC-49/U
NUMBER OF LEADS	STANDARD	2 LEADS
	OPTION	3 LEADS
SMD-VERSION		AVAILABLE WITH BENT LEADS AND METAL JACKET
PACKAGE HEIGHT	STANDARD	13.46 MM
	OPTION	10.7 MM
FREQUENCY		28.63636 MHz
MODE OF VIBRATION		3rd OVERTONE
RESONANCE RESISTANCE		40 Ω MAX.
FREQUENCY TOLERANCE AT 25°C		+50 PPM
TEMPERATURE RANGE		-10/+60°C
TEMPERATURE ATABILITY		+50 PPM
LOAD CAPACITANCE		30 PF
SHUNT CAPACITANCE		7 PF MAX.
DRIVE LEVEL		0.1 mW
AGING		+3 ~ +5 PPM PER YEAR
INSULATION RESISTANCE		>500 MΩ DC/100V +-10%
DELIVERY FORM FOR LEADED VERSION	STANDARD	BULKS
	OPTION	TAPE AND REEL (1.000 PCS PER REEL)
DELIVERY FORM FOR SMD-VERSION		TAPE AND REEL
INSULATOR FOR LEADED VERSION	STANDARD	WITHOUT INSULATOR
	OPTION	WITH INSULATOR
CUTTED LEADS		AVAILABLE ON REQUEST
<b>OTHER PARAMETERS ARE AVAILABLE ON REQUEST / CREATE HERE YOUR SPECIFICATION</b>		

## PART NUMBERING SYSTEM

<b>EXAMPLE</b>	HC-49/U 28.63636 MHz BT848A T/I
----------------	---------------------------------

TYPE	HC-49/U FOR TYPE WITH 2 LEADS
	HC-49/3U FOR TYPE WITH 3 LEADS
	HC-49/U-SMD FOR SMD-VERSION
PACKAGE HEIGHT	BLANK FOR 13.46 MM
	10.7 FOR 10.7 MM
PROCESSOR TYPE	BT848A OR BT878A
DELIVERY FORM	BLANK FOR BULKS
	T FOR TAPE AND REEL
INSULATOR	BLANK = WITHOUT INSULATOR
	I = WITH INSULATOR

OUTLINE DRAWING OF HC-49/U

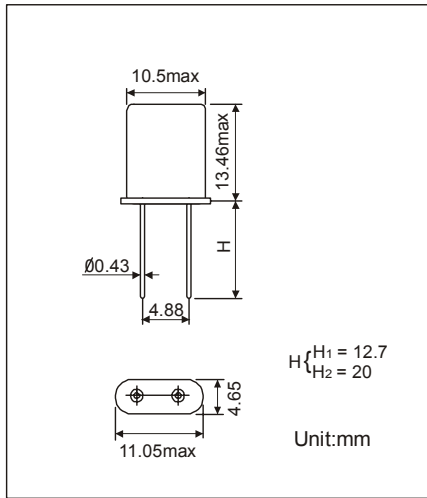

OUTLINE DRAWING OF HC-49/3U

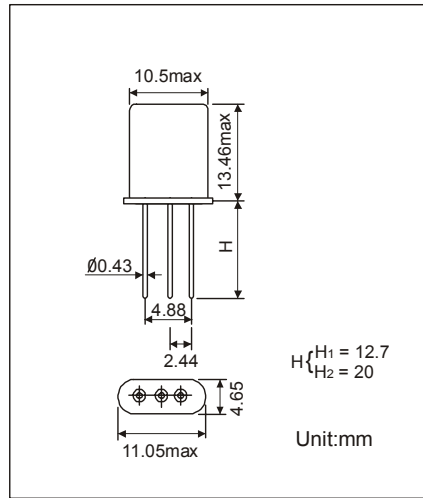

OUTLINE DRAWING OF HC-49/U-SMD

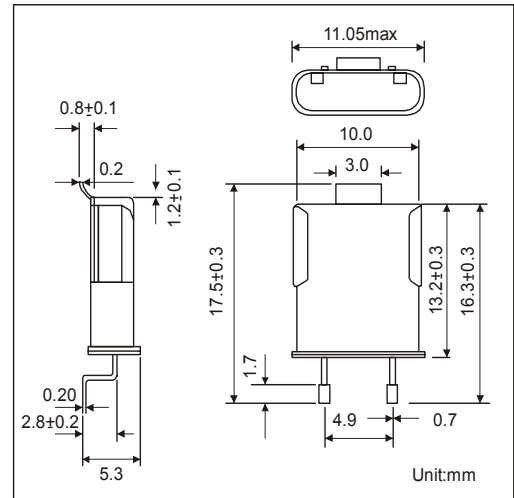

REEL SPECIFICATION (LEADED VERSION)

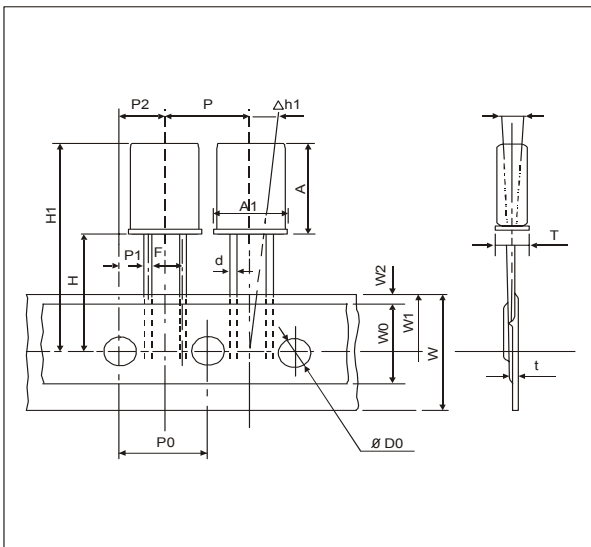

Description	Symbol	Dimensions
Outside Diameter of Part	AxA1	13.5x11.1
Thickness of Part	T	5.0max
Lead Wire Diameter	d	Ø0.43 <sup>+0.05</sup> / <sub>-0.02</sub>
Interval Spacing of Part	P	12.7±1.0
Pitch fo Leading Hole	P0	12.7±1.0
Tolerance of Leading Hole	P1	3.85±0.7
	P2	6.35±1.0
Lead Pitch	F	5.0 <sup>+0.5</sup> / <sub>-0.2</sub>
Inclination	Δ h	0±1.0
Tape Width	W	18.2±0.2
Adhesive Tape Width	W0	13.0 <sup>+0.8</sup> / <sub>-0.2</sub>
Tolerance of Leading Hole (Vertical)	W1	8.5±0.3
Tolerance of Cover Tape	W2	2.0max
Bottom Surface Position of Part	H	18.2±0.2
Top Surface Position of Part	H1	33.6max
Hole Diameter	D0	Ø4.0±0.2
Tape Thickness	t	0.7±0.1
Inclination	Δ h1	0±1.0

Unit:mm

REEL SPECIFICATION FOR SMD VERSION

