

FEATURES

- HIGH RELIABILITY FOR LOW COST
- WIDE FREQUENCY RANGE
- FREQUENCY STABILITY OF +/-10 PPM AVAILABLE
- AVAILABLE IN 5.0 AND 3.3 VOLT
- CHEAPEST AVAILABLE LEADED VCXO
- EXTENDED TEMPERATURE RANGE TO -40/+85°C AVAILABLE
- APPLICATIONS: FIBER CHANEL, GIGABIT ETHERNET, SET-TOP BOX, BROADBAND, TELECOM, ETC.

PROCESSOR TYPE		SGS THOMSON STI 5512		
SERIES		VCXO		
PACKAGES		14 DIP OR 8 DIP		
FREQUENCY		27.000 MHz		
FREQUENCY STABILITY		+25 PPM		
OPERATING TEMPERATURE		0/+70°C		
STORAGE TEMPERATURE RANGE		-40/+85°C		
INPUT		VOLTAGE	+5.0 VDC +5%	
		CURRENT	35 mA MAX.	
OUTPUT	SYMMETRY		40/60%	
	SIGNAL		CMOS	
	RISE AND FALL TIME		10 ns max.	
	"0" LEVEL		0.1 VDD MAX.	
	"1" LEVEL		0.9 VDD MIN.	
LOAD		15 PF MAX.		
START-UP TIME		10 mS max.		
INPUT IMPEDANCE		50 kΩ min.		
CONTROL VOLTAGE RANGE		0.5 ~ 4.5 VDC		
CENTER VOLTAGE		2.5 VDC		
PULLABILITY		+-100 ppm min.		
LINEARITY		10% max.		
SLOPE		POSITIVE		
PIN CONNECTION		PACKAGE	14 DIP	8 IP
		CONTROL VOLTAGE	PIN# 1	PIN# 1
		GROUND	PIN# 7	PIN# 4
		OUTPUT	PIN# 8	PIN# 5
		INPUT VOLTAGE	PIN# 14	PIN# 8
OTHER PARAMETERS ARE AVAILABLE ON REQUEST / CREATE HERE YOUR SPECIFICATION				

PART NUMBERING SYSTEM

EXAMPLE	VCXO DIP8 27.000 MHz THOMSON STI 5512
SERIES	VCXO
PACKAGE	DIP 14 OR DIP 8
PROCESSOR TYPE	SGS THOMSON STI 5512

OUTLINE DRAWING OF DIP 14

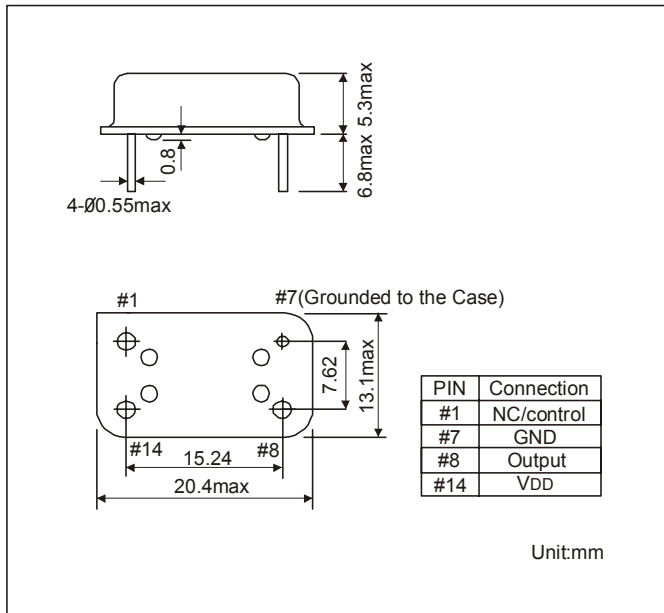

OUTLINE DRAWING OF DIP 8

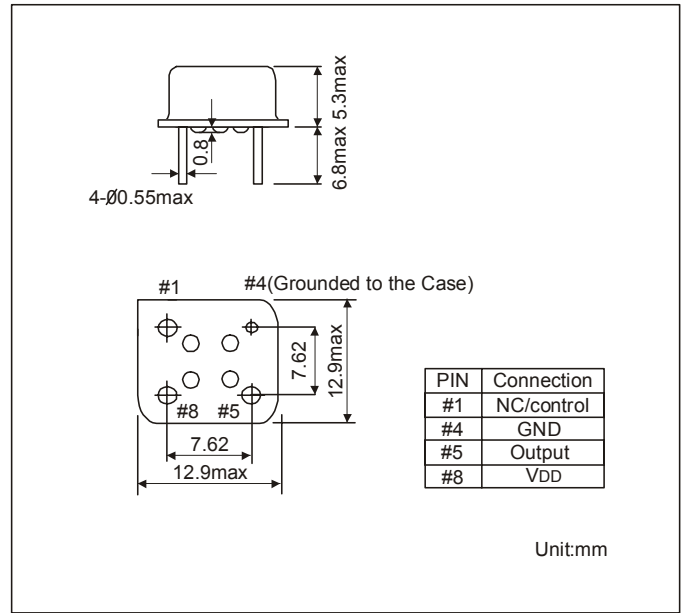

TEST CIRCUIT

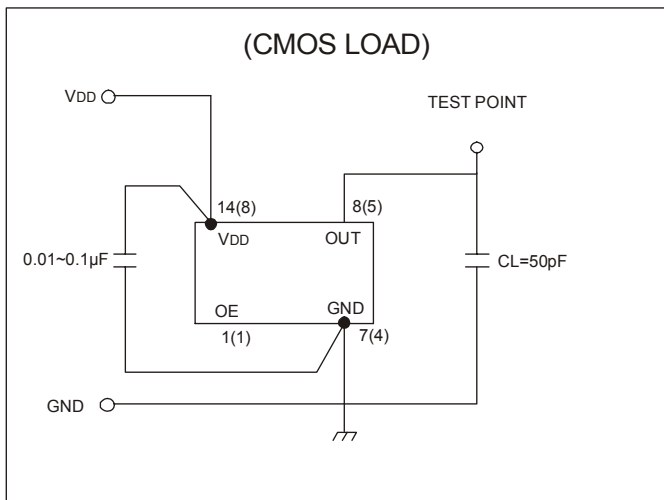

RECOMMENDED PIN CONNECTION

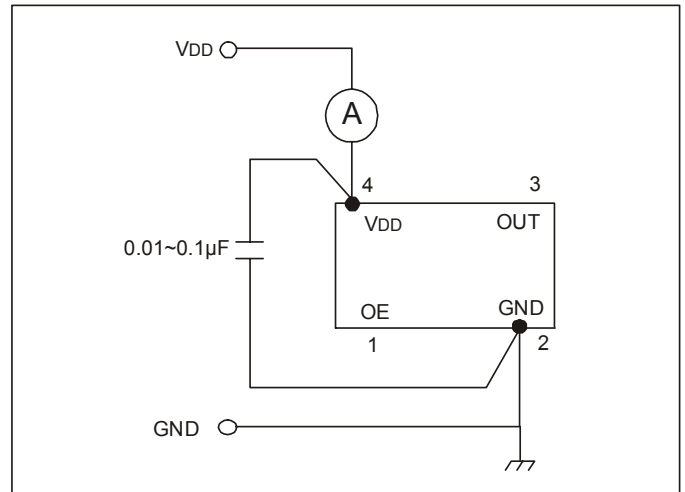

OUTPUT WAVE FORM OF CMOS

