

DIFFERENTIAL LOW POWER SPREAD SPECTRUM OSCILLATOR

SERIES „DLPSSO“

1.0–220.0 MHz

FEATURES

- + 100% pin-to-pin drop-in replacement to quartz and MEMS based XO
- + Differential Low Power Spread Spectrum Oscillator for Low Cost
- + Excellent long time reliability - outperforms quartz-based XO
- + Wide frequency range
 - 1 MHz to 220 MHz
 - 220 MHz to 800 MHz (contact Petermann-Technik)
- + Extremely low cycle-cycle jitter: as low as 10 ps (typical)
- + Eight spread selections (31.5 KHz modulation rate)
 - Center Spread: $\pm 0.25\%$, $\pm 0.5\%$, $\pm 1.0\%$, $\pm 2.0\%$
 - Down Spread: -0.5% , -1.0% , -2.0% , -4.0%
 - For -0.25% and $\pm 0.125\%$ contact Petermann-Technik
- + Low frequency stability (Spread = OFF) ± 25 ppm or ± 50 ppm
- + Operating voltage of 1.8V, 2.5V or 3.3 V
- + Ultra-reliable start up and greater immunity from interference
- + Express samples within 1 day ex works
- + Pb-free, RoHS and REACH compliant / MSL1@260°C

APPLICATIONS

- + PCI-Express
- + USB 3.0
- + Fully Buffered DIMM
- + Blade Server
- + Router
- + System Clock
- + Networking and Computing
- + Automotive
- + Industrial
- + etc.

DC GENERAL DATA

PARAMETER AND CONDITIONS	SYMBOL	MIN.	TYP.	MAX.	UNIT	CONDITION
LVCMOS INPUT, OE OR ST PIN, 3.3V $\pm 10\%$ OR 2.5V $\pm 10\%$ OR 1.8V $\pm 5\%$, -40 TO 85°C						
Input High Voltage	V _{IH}	70	-	-	%V _{dd}	
Input Low Voltage	V _{IL}	-	-	30	%V _{dd}	
Input High Current	I _{IH}	-	-	10	uA	OE or ST or SD pin
Input Low Current	I _{IL}	-10	-	-	uA	OE or ST or SD pin
Power Up Time	T _{pu}	-	-	10	ms	Time from minimum power supply voltage to the first cycle (Guaranteed no runt pulses)
LVPECL, 3.3V $\pm 10\%$ OR 2.5V $\pm 10\%$, -40 TO 85°C						
Supply Voltage	V _{DD}	2.97	3.3	3.63	V	
		2.25	2.5	2.75	V	
Supply Current	I _{DD}	-	75	84	mA	V _{DD} = 3.3, Excluding Load Termination Current
		-	75	84	mA	V _{DD} = 2.5, Excluding Load Termination Current
Output High Voltage	V _{OH}	V _{DD} -1.1	-	V _{DD} -0.7	V	50 Ohm termination to V _{DD} - 2.0V See Figure 2,3.
Output Low Voltage	V _{OL}	V _{DD} -2.0	-	V _{DD} -1.4	V	
Pk-Pk Output Voltage Swing	V _{swing}	600	800	1000	mV	
HCSL, 3.3V $\pm 10\%$ OR 2.5V $\pm 10\%$, -40 TO 85°C						
Supply Voltage	V _{DD}	2.97	3.3	3.63	V	
		2.25	2.5	2.75	V	
Supply Current	I _{DD}	-	73	80	mA	V _{DD} = 3.3, Excluding Load Termination Current
		-	73	80	mA	V _{DD} = 2.5, Excluding Load Termination Current
Output High Voltage	V _{OH}	0.6	0.75	0.95	V	50 Ohm termination to GND See Figure 4.
Output Low Voltage	V _{OL}	0.0	-	50	mV	
Pk-Pk Output Voltage Swing	V _{swing}	600	750	950	mV	
EXCELLENT RELIABILITY DATA						
MTBF						500 million hours
Shock Resistance						10.000 g
Vibration Resistance						70 g

DC GENERAL DATA (continued)

PARAMETER AND CONDITIONS	SYMBOL	MIN.	TYP.	MAX.	UNIT	CONDITION
LVDS, 3.3V ± 10% OR 2.5V ± 10%, -40 TO 85°C						
Supply Voltage	VDD	2.97	3.3	3.63	V	
		2.25	2.5	2.75	V	
Supply Current	IDD	-	75	85	mA	VDD = 3.3, Excluding Load Termination Current
		-	70	77	mA	VDD = 2.5, Excluding Load Termination Current
Differential Output Voltage	VOD1	250	350	450	mV	Swing Mode = Normal
VOD Magnitude Change	ΔVOD1	-	-	50	mV	Single load termination.
Offset Voltage	VOS1	-	1.2	-	V	See Figure 5.
VOS Magnitude Change	ΔVOS1	-	-	50	mV	
Differential Output Voltage	VOD2	500	700	900	mV	Swing Mode = High
VOD Magnitude Change	ΔVOD2	-	-	50	mV	Single load termination.
Offset Voltage	VOS2	-	1.2	-	V	See Figure 5.
VOS Magnitude Change	ΔVOS2	-	-	50	mV	
Differential Output Voltage	VOD3	250	350	450	mV	Swing Mode = High
VOD Magnitude Change	ΔVOD3	-	-	50	mV	Double load termination.
Offset Voltage	VOS3	-	1.2	-	V	See Figure 6.
VOS Magnitude Change	ΔVOS3	-	-	50	mV	
CML, 3.3V ± 10% OR 2.5V ± 10% OR 1.8V ± 5%, -40 TO 85°C						
Supply Voltage	VDD	2.97	3.3	3.63	V	
		2.25	2.5	2.75	V	
		1.71	1.8	1.89	V	
Supply Current	IDD	-	48	51	mA	VDD = 3.3V, Excluding Load Termination Current
		-	48	51	mA	VDD = 2.5V, Excluding Load Termination Current
		-	48	51	mA	VDD = 1.8V, Excluding Load Termination Current
Output High Voltage	VOH1	VDD-0.1	-	VDD	V	Swing Mode = Normal
Output Low Voltage	VOL1	VDD-0.55	VDD-0.425	VDD-0.3	V	Single load termination.
Pk-Pk Output Voltage Swing	Vswing1	300	425	550	mV	See Figure 7.
Output High Voltage	VOH2	VDD-0.1	-	VDD	V	Swing Mode = High
Output Low Voltage	VOL2	VDD-1.1	VDD-0.85	VDD-0.6	V	Single load termination.
Pk-Pk Output Voltage Swing	Vswing2	600	850	1100	mV	See Figure 7.
Output High Voltage	VOH3	VDD-0.1	-	VDD	V	Swing Mode = High
Output Low Voltage	VOL3	VDD-0.55	VDD-0.425	VDD-0.3	V	Double load termination.
Pk-Pk Output Voltage Swing	Vswing3	300	425	550	mV	See Figure 8.

AC GENERAL DATA

PARAMETER AND CONDITIONS	SYMBOL	MIN.	TYP.	MAX.	UNIT	CONDITION
LVPECL, 3.3V ± 10%, -40 TO 85°C						
Output Frequency	F_out	1.0	-	220	MHz	
Frequency Stability	F_stab	-25	-	+25	PPM	-20 to 70°C Inclusive of initial stability, operating temp.,
		-50	-	+50	PPM	-40 to 85°C rated power supply voltage change, load change
Aging	F_age	-	-	1	PPM	First year @ 25°C
Duty Cycle	DC	45	-	55	%	
Output Rise/Fall Time	tR/tF	100	150	300	ps	20% to 80%
Cycle-Cycle Jitter	T_ccj	-	10	16	ps	Fout = 100 MHz, -0.5% down spread
		-	8	14	ps	Fout = 150 MHz, -0.5% down spread
		-	8	14	ps	Fout = 200 MHz, -0.5% down spread
LVPECL, 2.5V ± 10%, -40 TO 85°C						
Output Frequency	F_out	1.0	-	220	MHz	
Frequency Stability	F_stab	-25	-	+25	PPM	-20 to 70°C Inclusive of initial stability, operating temp.,
		-50	-	+50	PPM	-40 to 85°C rated power supply voltage change, load change
Aging	F_age	-	-	1	PPM	First year @ 25°C
Duty Cycle	DC	45	-	55	%	
Output Rise/Fall Time	tR/tF	100	150	300	ps	20% to 80%
Cycle-Cycle Jitter	T_ccj	-	10	16	ps	Fout = 100 MHz, -0.5% down spread
		-	8	14	ps	Fout = 150 MHz, -0.5% down spread
		-	8	14	ps	Fout = 200 MHz, -0.5% down spread
HCSL, 3.3V ± 10%, -40 TO 85°C						
Output Frequency	F_out	1.0	-	220	MHz	
Frequency Stability	F_stab	-25	-	+25	PPM	-20 to 70°C Inclusive of initial stability, operating temp.,
		-50	-	+50	PPM	-40 to 85°C rated power supply voltage change, load change
Aging	F_age	-	-	1	PPM	First year @ 25°C
Duty Cycle	DC	45	-	55	%	
Output Rise/Fall Time	tR/tF	200	280	375	ps	20% to 80%
Cycle-Cycle Jitter	T_ccj	-	10	16	ps	Fout = 100 MHz, -0.5% down spread
		-	10	15	ps	Fout = 150 MHz, -0.5% down spread
		-	10	15	ps	Fout = 200 MHz, -0.5% down spread
HCSL, 2.5V ± 10%, -40 TO 85°C						
Output Frequency	F_out	1.0	-	220	MHz	
Frequency Stability	F_stab	-25	-	+25	PPM	-20 to 70°C Inclusive of initial stability, operating temp.,
		-50	-	+50	PPM	-40 to 85°C rated power supply voltage change, load change
Aging	F_age	-	-	1	PPM	First year @ 25°C
Duty Cycle	DC	45	-	55	%	
Output Rise/Fall Time	tR/tF	200	300	400	ps	20% to 80%
Cycle-Cycle Jitter	T_ccj	-	9	19	ps	Fout = 100 MHz, -0.5% down spread
		-	9	17	ps	Fout = 150 MHz, -0.5% down spread
		-	9	15	ps	Fout = 200 MHz, -0.5% down spread

AC GENERAL DATA (continued)

PARAMETER AND CONDITIONS	SYMBOL	MIN.	TYP.	MAX.	UNIT	CONDITION
LVDS, 3.3V ± 10%, -40 TO 85°C						
Output Frequency	F _{out}	1.0	-	220	MHz	
Frequency Stability	F _{stab}	-25	-	+25	PPM	-20 to 70°C Inclusive of initial stability, operating temp.,
		-50	-	+50	PPM	-40 to 85°C rated power supply voltage change, load change
Aging	F _{age}	-	-	1	PPM	First year @ 25°C
Duty Cycle	DC	45	-	55	%	
Output Rise/Fall Time	t _R /t _F	100	200	325	ps	20% to 80%
Cycle-Cycle Jitter	T _{CCJ}	-	11	19	ps	F _{out} = 100 MHz, -0.5% down spread
		-	11	20	ps	F _{out} = 150 MHz, -0.5% down spread
		-	11	21	ps	F _{out} = 200 MHz, -0.5% down spread
LVDS, 2.5V ± 10%, -40 TO 85°C						
Output Frequency	F _{out}	1.0	-	220	MHz	
Frequency Stability	F _{stab}	-25	-	+25	PPM	-20 to 70°C Inclusive of initial stability, operating temp.,
		-50	-	+50	PPM	-40 to 85°C rated power supply voltage change, load change
Aging	F _{age}	-	-	1	PPM	First year @ 25°C
Duty Cycle	DC	45	-	55	%	
Output Rise/Fall Time	t _R /t _F	100	260	325	ps	20% to 80%
Cycle-Cycle Jitter	T _{CCJ}	-	14	26	ps	F _{out} = 100 MHz, -0.5% down spread
		-	14	26	ps	F _{out} = 150 MHz, -0.5% down spread
		-	14	27	ps	F _{out} = 200 MHz, -0.5% down spread
CML, 3.3V ± 10%, -40 TO 85°C						
Output Frequency	F _{out}	1.0	-	220	MHz	
Frequency Stability	F _{stab}	-25	-	+25	PPM	-20 to 70°C Inclusive of initial stability, operating temp.,
		-50	-	+50	PPM	-40 to 85°C rated power supply voltage change, load change
Aging	F _{age}	-	-	1	PPM	First year @ 25°C
Duty Cycle	DC	45	-	55	%	
Output Rise/Fall Time	t _R /t _F	150	220	300	ps	20% to 80%
Cycle-Cycle Jitter	T _{CCJ}	-	11	20	ps	F _{out} = 100 MHz, -0.5% down spread
		-	11	18	ps	F _{out} = 150 MHz, -0.5% down spread
		-	10	19	ps	F _{out} = 200 MHz, -0.5% down spread
CML, 2.5V ± 10%, -40 TO 85°C						
Output Frequency	F _{out}	1.0	-	220	MHz	
Frequency Stability	F _{stab}	-25	-	+25	PPM	-20 to 70°C Inclusive of initial stability, operating temp.,
		-50	-	+50	PPM	-40 to 85°C rated power supply voltage change, load change
Aging	F _{age}	-	-	1	PPM	First year @ 25°C
Duty Cycle	DC	45	-	55	%	
Output Rise/Fall Time	t _R /t _F	150	230	300	ps	20% to 80%
Cycle-Cycle Jitter	T _{CCJ}	-	13	22	ps	F _{out} = 100 MHz, -0.5% down spread
		-	12	19	ps	F _{out} = 150 MHz, -0.5% down spread
		-	11	20	ps	F _{out} = 200 MHz, -0.5% down spread

AC GENERAL DATA (continued)

PARAMETER AND CONDITIONS	SYMBOL	MIN.	TYP.	MAX.	UNIT	CONDITION
CML, 1.8V ± 5%, -40 TO 85°C						
Output Frequency	F_out	1.0	-	220	MHz	
Frequency Stability	F_stab	-25	-	+25	PPM	-20 to 70°C Inclusive of initial stability, operating temp.,
		-50	-	+50	PPM	-40 to 85°C rated power supply voltage change, load change
Aging	F_age	-	-	1	PPM	First year @ 25°C
Duty Cycle	DC	45	-	55	%	
Output Rise/Fall Time	tR/tF	150	230	300	ps	20% to 80%
Cycle-Cycle Jitter	T_ccj	-	13	23	ps	Fout = 100 MHz, -0.5% down spread
		-	12	22	ps	Fout = 150 MHz, -0.5% down spread
		-	12	21	ps	Fout = 200 MHz, -0.5% down spread

PIN DESCRIPTION

PIN	SYMBOL		FUNCTIONALITY
1	$\overline{ST/OE/SD}$	Input	Standby or Output Enable pin for OUT+ and OUT-. OE: When High or Open : OUT+ and OUT- = active When Low : OUT+ and OUT- = High Impedance state ST: When High or Open : OUT+ and OUT- = active When Low : OUT+ and OUT- = Output is low (weak pull down), oscillation stops SD: Spread Disable - disables spread spectrum When High or Open : Spread Spectrum modulation = active When Low : Spread Spectrum modulation = Off
2	NC	NA	No connect pin, leave it floating.
3	GND	Power	VDD power supply ground. Connect to ground
4	OUT+	Output	1 to 220 MHz programmable clock output. For frequencies
5	OUT-	Output	> 220 MHz contact Petermann-Technik
6	VDD	Power	Power Supply

TOP VIEW

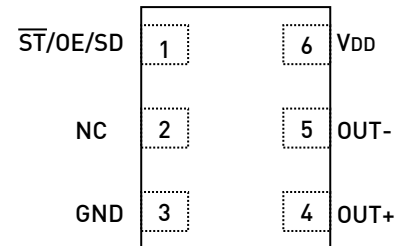

TERMINATION DIAGRAMS

FIGURE 1. LVPECL AC COUPLED TYPICAL TERMINATION
DLPSS0 (LVPECL-0)

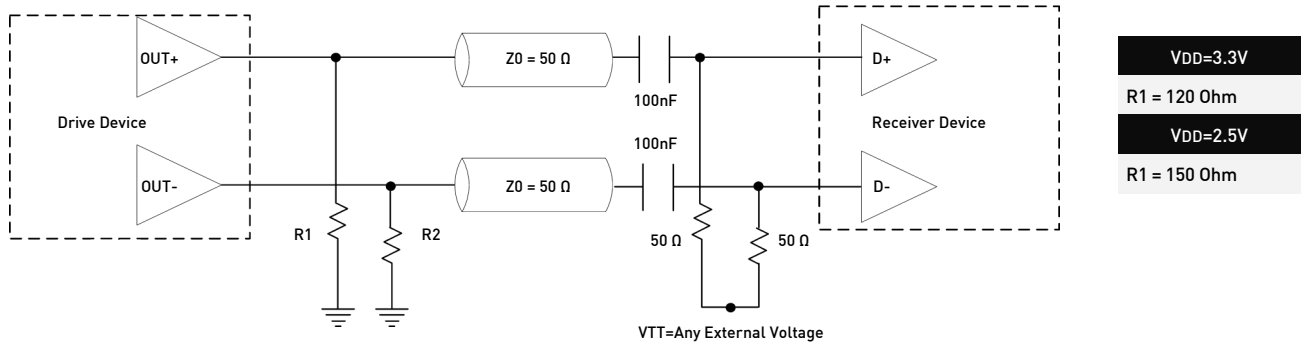

FIGURE 2. LVPECL DC COUPLED TYPICAL TERMINATION
WITH TERMINATION VOLTAGE DLPS0 (LVPECL-1)

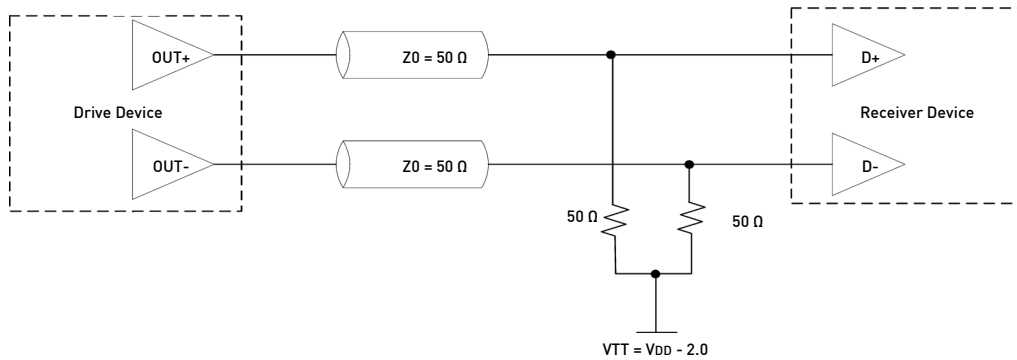
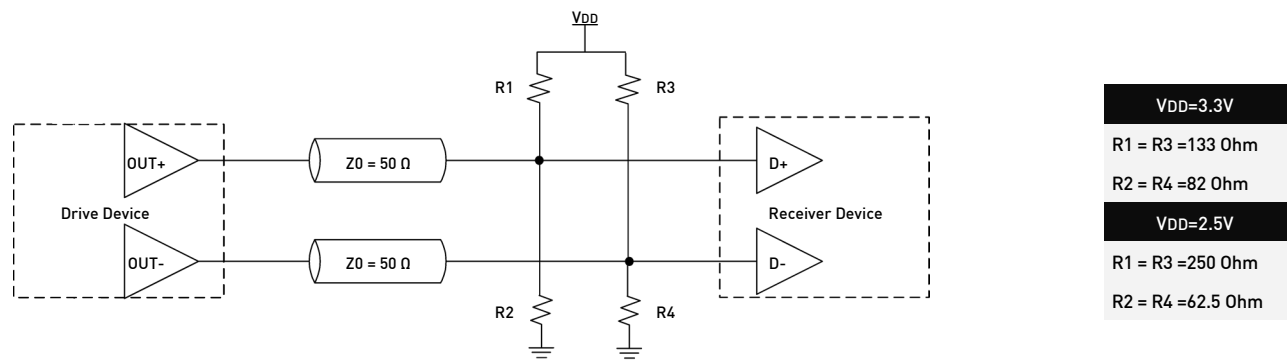
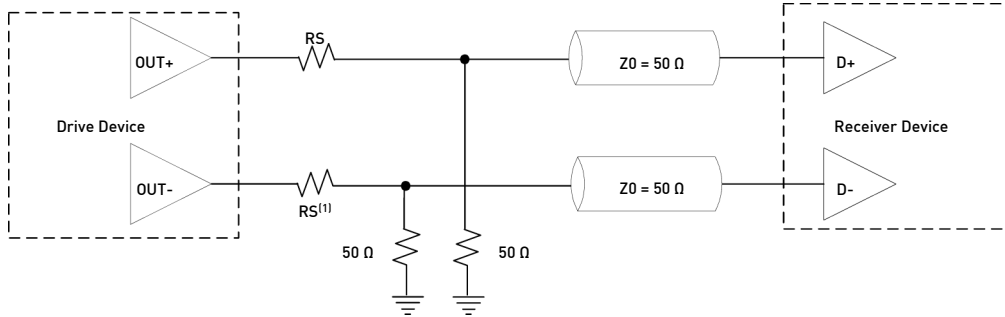

FIGURE 3. LVPECL DC COUPLED TYPICAL TERMINATION
WITHOUT TERMINATION VOLTAGE DLPS0 (LVPECL-1)



TERMINATION DIAGRAMS (continued)

FIGURE 4. HCSSL TYPICAL TERMINATION
 DLPSS0



RS=10 Ohm to 35 Ohm

Note: 1. All the tests are done with RS = 20 Ohm (recommended).

FIGURE 5. LVDS SINGLE LOAD TERMINATION (LOAD TERMINATED)
 DLPSS0

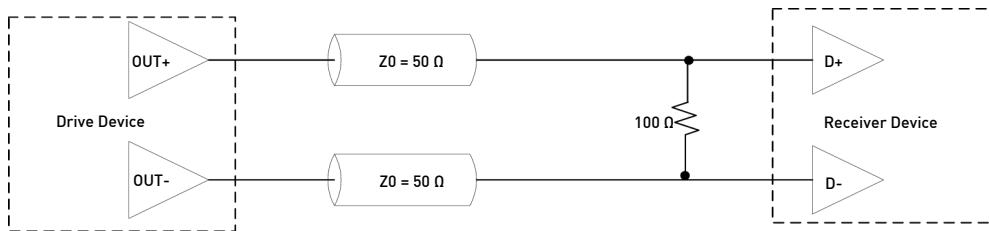
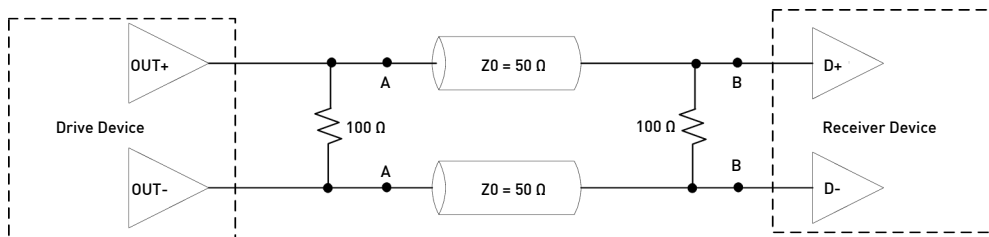

FIGURE 6. LVDS DOUBLE TERMININATION (SOURCE + LOAD TERMINATED)⁽²⁾
 DLPSS0



Note: 2. For AC coupled operation, include/insert decoupling caps at points A or B.

TERMINATION DIAGRAMS (continued)

FIGURE 7. CML SINGLE LOAD TERMINATION
 DLPSS0

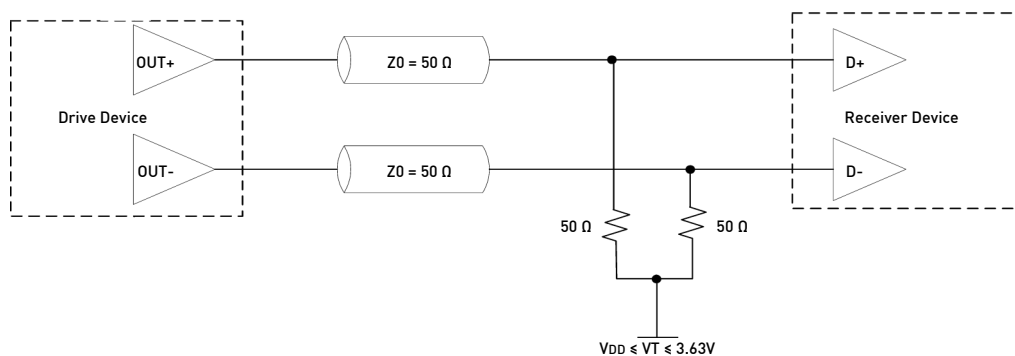
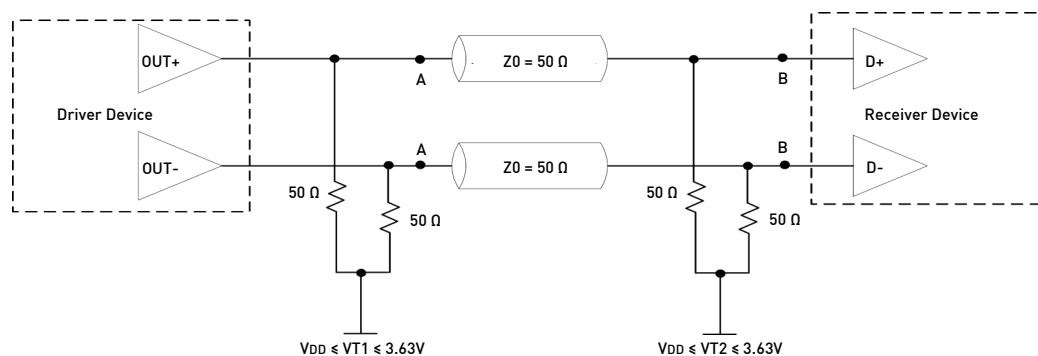

FIGURE 8. CML DOUBLE LOAD TERMINATION
 DLPSS0



Notes: 3. For DC-coupled operation, $VT1 = VT2$

4. For AC coupled operation, include/insert decoupling caps at points A or B

5. For AC-coupled operation with capacitors placed at point A, $VT2$ sets the input common mode of Receiver Device and need not to be related to $VT1$

DIMENSIONS AND PATTERNS

PACKAGE SIZE – DIMENSIONS (UNIT:MM)

5.0X 3.2 X 0.75 MM

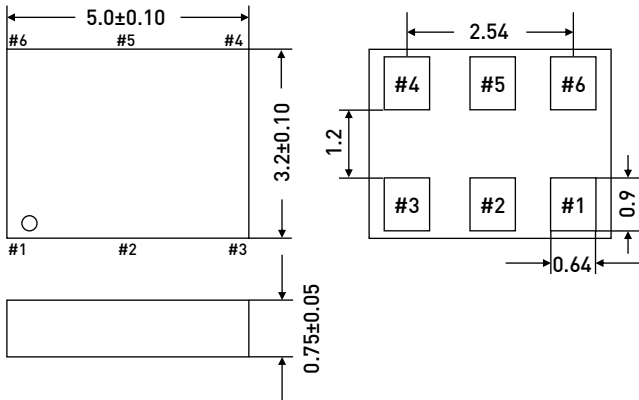

RECOMMENDED LAND PATTERN (UNIT:MM) ^[6]

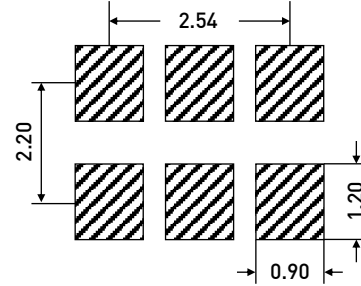

PACKAGE SIZE – DIMENSIONS (UNIT:MM)

7.0X 5.0 X 0.90 MM

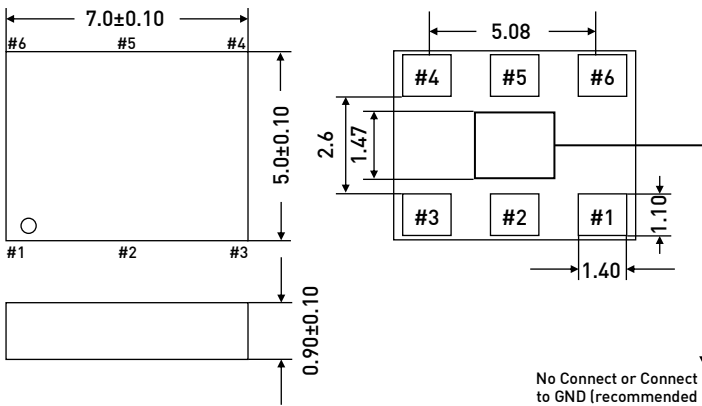

RECOMMENDED LAND PATTERN (UNIT:MM)

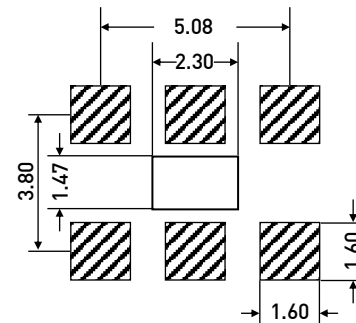

REFLOW SOLDER PROFILE

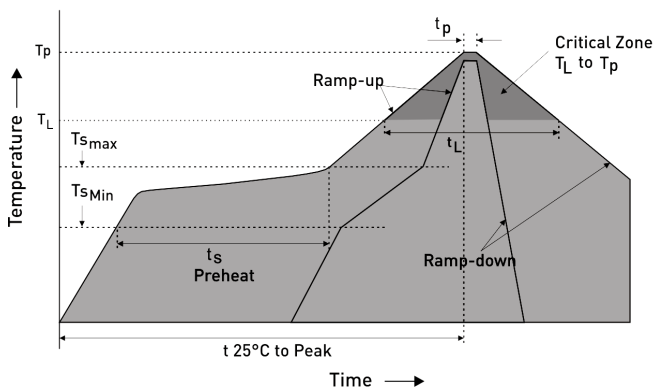

IPC/JEDEC Standard	IPC/JEDEC J-STD-020
Moisture Sensitivity Level	Level 1
TS MAX to TL (Ramp-up Rate)	3°C/second Maximum
Preheat	
- Temperature Minimum (TS MIN)	150°C
- Temperature Typical (TS TYP)	175°C
- Temperature Typical (TS MAX)	200°C
- Time (tS)	60 - 180 Seconds
Ramp-up Rate (TL to TP)	3°C/second Maximum
Time Maintained Above:	
- Temperature (TL)	217°C
- Time (TL)	60 - 150 Seconds
Peak Temperature (TP)	260°C Maximum
Target Peak Temperature (TP Target)	255°C
Time within 5°C of actual peak (tP)	20 - 40 Seconds
Max. Number of Reflow Cycles	3
Ramp-down Rate	6°C/second Maximum
Time 25°C to Peak Temperature (t)	8 minutes Maximum

Note: 6. A capacitor value of 0.1 μ F between VDD and GND is recommended.

ORDERING INFORMATION

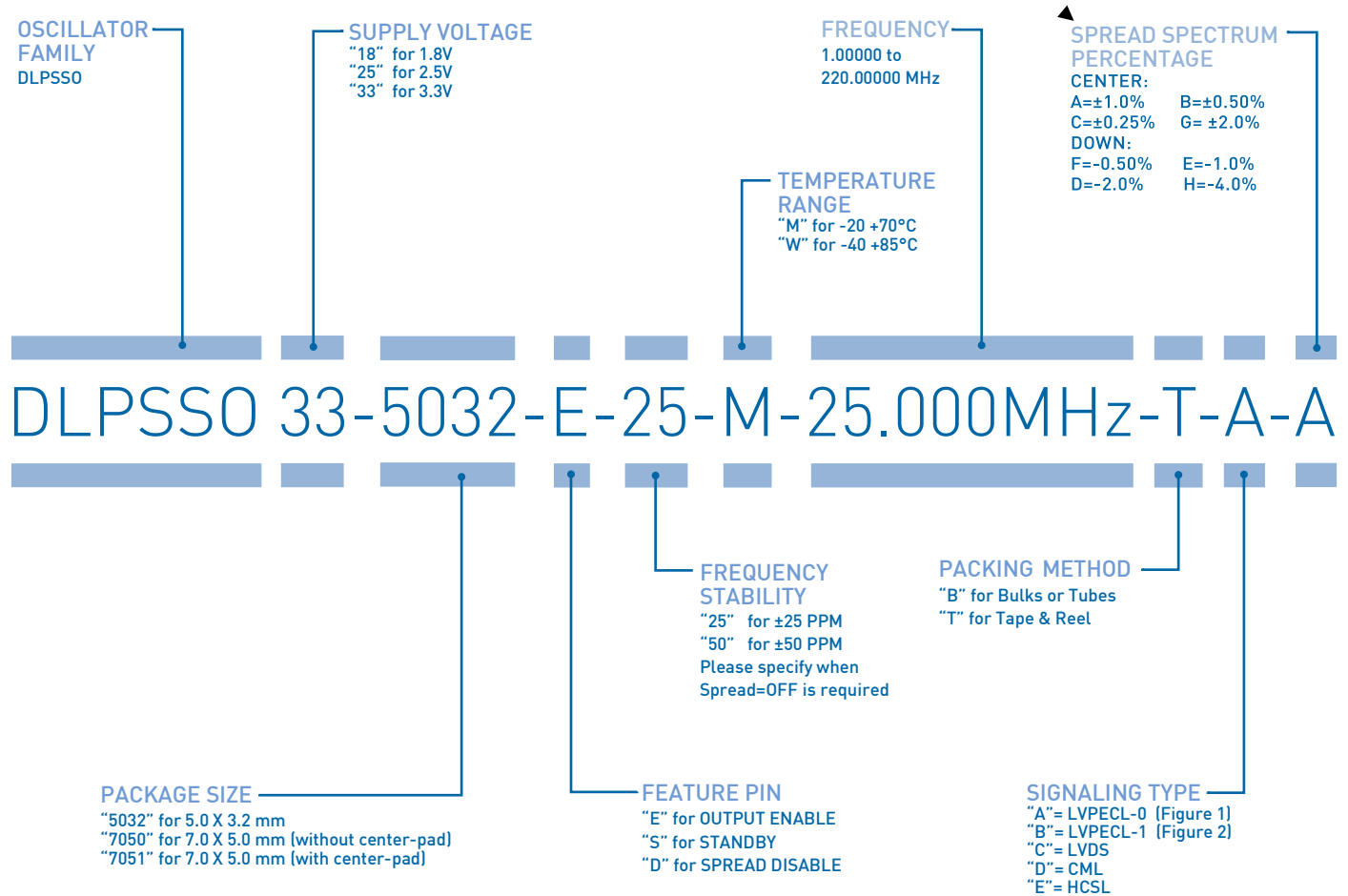

EXAMPLE: DLPSS0-33-5032-E-25-M-25.000MHZ-T-A-A
[PLEASE CLICK HERE TO CREATE YOUR OWN ORDERING CODE](#)

**EXPRESS SAMPLES ARE DELIVERABLE ON THE SAME DAY
IF ORDERED UNTIL 02:00 PM!**



PREMIUM QUALITY BY PETERMANN-TECHNIK



OUR COMPANY IS CERTIFIED ACCORDING TO ISO 9001:2008 IN OCTOBER 2013 BY THE DMSZ CERTIFIKATION GMBH.

THIS IS FOR YOU TO ENSURE THAT THE PRINCIPLES OF QUALITY MANAGEMENT ARE FULLY IMPLEMENTED IN OUR QUALITY MANAGEMENT SYSTEM AND QUALITY CONTROL METHODS ALSO DOMINATE OUR QUALITY STANDARDS.