

SMD WATCH CRYSTAL 32.768 kHz

SERIES „M1610 32.768 KHZ ±20 PPM 9PF (-40/+85°C)“

FEATURES

- + Excellent shock-resistance, robust ceramic package with metal lid
- + Ultra low profile
- + Standard operating temperature range of -40/+85°C
- + Excellent clock generator for CPU's, Wireless, Mobile Comm., etc.

GENERAL DATA

PARAMETERS	PRODUCT FEATURES AND CONDITIONS
SMD-CRYSTAL SERIES	M1610
NUMBER OF SOLDER PADS	2
FREQUENCY	32.768 kHz
FREQUENCY TOLERANCE AT 25°C	±20 ppm
LOAD CAPACITANCE (C _L)	9 pF
WORKING TEMPERATURE RANGE	-40/+85°C
SERIES RESISTANCE	90 kΩ max.
SHUNT CAPACITANCE (C ₀)	1.3 pF typ.
TURNOVER TEMPERATURE	+25°C ±5°C
TEMPERATURE COEFFICIENT	-0.03±0.01 ppm/°C ²
DRIVE LEVEL	0.1 μW±0.01 μW (0.5 μW max.)
AGING	±3 ppm first year, ±5 ppm / 5 years and ±10 ppm / 10 years max.
INSULATION RESISTANCE	>500 MΩ DC/100V ±10%
STORAGE TEMPERATURE	-40°/+85°C
DELIVERY FORM	Tape and Reel (5.000 pcs per reel, other quantities on request as cut off tape or bulks)
RoHS	Lead free and RoHS compliant
MARKING	Axxxx (xxxx = date code)
Ordering Code	M1610 32.768 kHz ±20 ppm 9pF (-40/+85°C)
Customer P/N	
PETERMANN-TECHNIK P/N	QEU10010052/1

Notes

1. The reference temperature for all specified values and tests is +25°C.
2. No Ultrasonic Cleaning: Do not subject the M1610 to an ultrasonic cleaning environment. Permanent damage or long term reliability issues to the structure may occur.
3. Do not design any ground line under the M1610.
4. Do not solder with hot air gun.

DIMENSIONS AND PATTERNS

PACKAGE SIZE – DIMENSIONS (UNIT:MM)
 1.6 X 1.0 X 0.5 MM

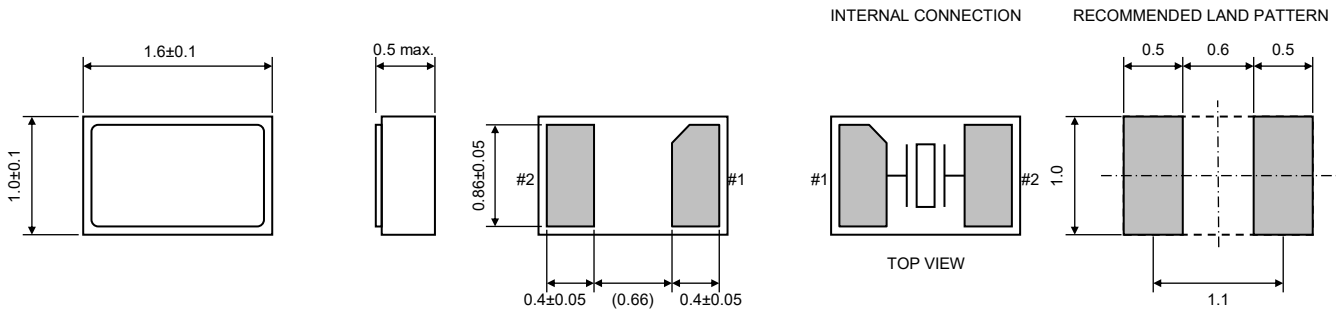

REFLOW SOLDER PROFILE

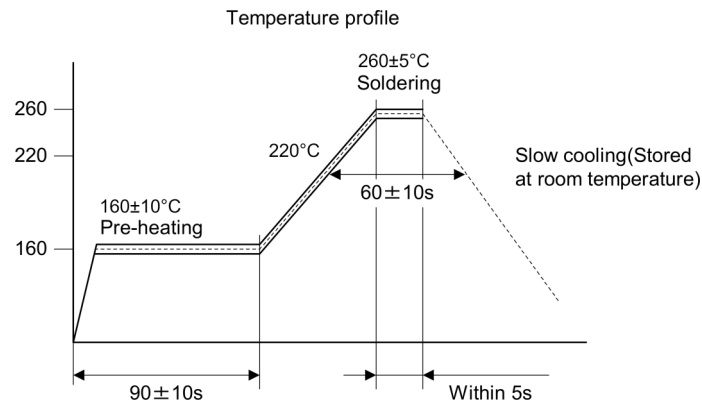

Peak temperature: $260 \pm 5^\circ\text{C}$ for within 5 seconds. Soldering temperature: 220°C or higher for 60 ± 10 seconds.
 Pre-heating temperature: $160 \pm 10^\circ\text{C}$ for 90 ± 10 seconds. Quartz crystal units which is put on PCB shall be through reflow soldering furnace twice with the condition shown above.



PREMIUM QUALITY BY PETERMANN-TECHNIK



OUR COMPANY IS CERTIFIED ACCORDING TO ISO 9001:2015 AND 14001:2015

THIS IS FOR YOU TO ENSURE THAT THE PRINCIPLES OF QUALITY MANAGEMENT ARE FULLY IMPLEMENTED IN OUR QM-SYSTEM AND QUALITY CONTROL METHODS.